

# Big Bubble Mixing Enhances Biological Nutrient Removal Performance in a Unique Modified Four-Stage Facility

Rosalyn Matthews, Derek Bieber, Kristi Fries, and Steve Shelnett

The City of Orlando (city) completed facility improvements in February 2016 at the Water Conserv II Water Reclamation Facility (WCIWRF) that enhanced the biological nutrient removal (BNR) within the facility basins. The key goal of the improvements was to provide mixing within the first anoxic basins to reduce dissolved oxygen concentrations and enhance denitrification.

The city wished to maximize the capacity and treatment capabilities within the BNR process. Prior to the project, mixing of the anoxic zones was accomplished through the addition of

a low level of diffused air. A similar level of low aeration is used within the “second anoxic” zones within aeration basins 5-10; however, it was determined that even low levels of air increased the dissolved oxygen (DO) level enough to impact denitrification within the basins. To improve mixing within the basins and reduce DO levels, two alternatives were proposed: hyperboloid mixers and big bubble mixing technology, both of which have been used in the municipal wastewater industry. The purpose of the project was to evaluate both technologies on performance and net-present-worth comparisons.

*Rosalyn Matthews, Ph.D., P.E., is an associate with Hazen and Sawyer in Cleveland, and Derek Bieber, P.E., is senior principal engineer with Hazen and Sawyer in Orlando. Kristi Fries, P.E., is a project manager and Steve Shelnett is plant manager for Water Conserv II with City of Orlando.*

## Facility Description

The city owns and operates WCIWRF. The 21-mil-gal-per-day (mgd) annual average daily flow (AADF) facility consists of flow equalization, preliminary treatment, biological nutrient removal (BNR), clarification, dual media filters, and disinfection. Solids handling includes thickening, a proprietary lime stabilization process, and dewatering.

## Biological Nutrient Removal Schematic

The BNR process consists of two trains: the north train consists of basins 1, 3, 5, 7, and 9, while the south train consists of basins 2, 4, 6, 8, and 10. The ten basins are located in two sets of consecutive rectangular tanks: basins 1-4 are located in the first tank and basins 5-10 are located in the subsequent tank.

The improvements redirected the flow path within basins 1-4 and constructed a mixing system for basins 3 and 4. Prior to the project, a low flow of diffused aeration was used to provide mixing within the anoxic basins; however, the small amount of aeration resulted in suboptimal performance. The redirection of the internal recycle flow from basins 3 and 4 to basins 1 and 2 allowed for the process to use the basins with the highest fine bubble diffuser density for aerobic zones.

The current flow path sends influent flow, return activated sludge (RAS), and internal recycle (IR) through the anoxic zones in basins 3 and 4. The IR pumps deliver approximately two times the influent flow from the effluent channel of basins 3 and 4 over the wall and into basins 1 and 2 where it flows in the reverse direction. Basins 1 and 2 aerate the IR with high-efficiency diffusers

*Continued on page 8*

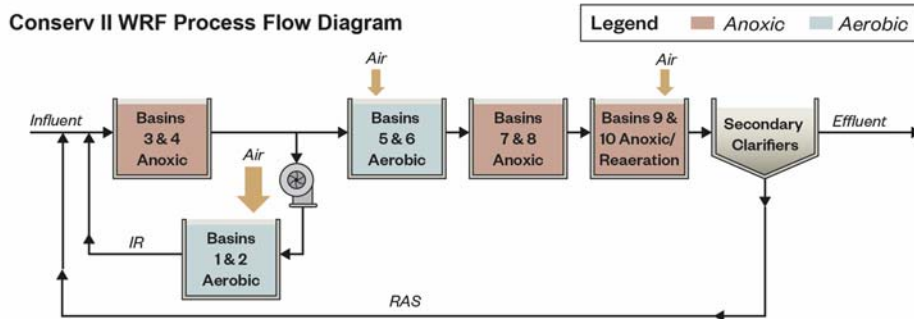

Figure 1. Conserv II Water Reclamation Facility Biological Nutrient Removal Process Flow Diagram

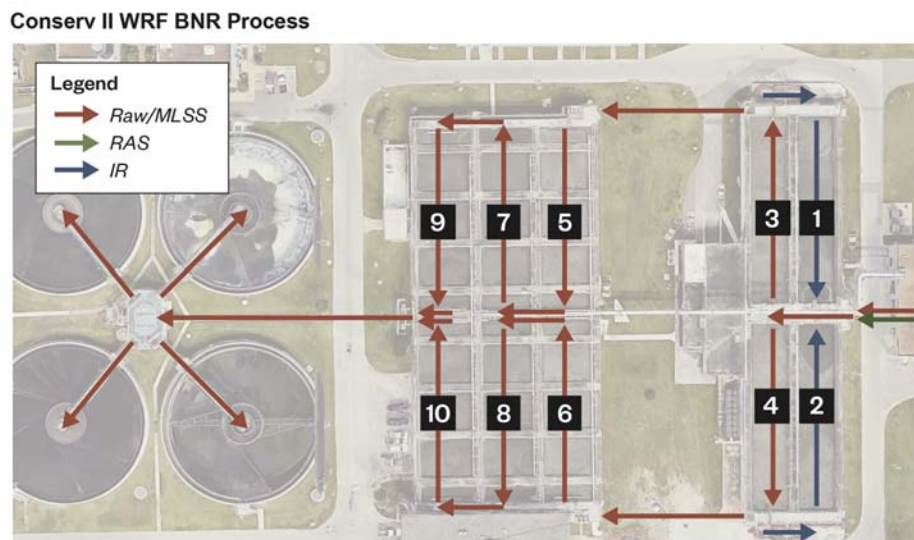

Figure 2. Conserv II Water Reclamation Facility Biological Nutrient Removal Aerial Flow

Continued from page 6

and the flow is recombined with the raw and RAS flow going to basins 3 and 4. After these four basins, the flow continues to basins 5-10, where it flows in a serpentine pattern.

A portion of basins 5-10 is maintained with minimum aeration to create a "secondary anoxic zone." The facility uses online nutrient

monitoring to adjust performance parameters within the basins, such as airflow and IR. Figure 1 presents the process flow diagram of the biological system and Figure 2 presents the liquid flow and IR loop within basins 1-4.

### Permit Limits

The effluent quality limits of WCIIWRF have

three permitted discharges: local public access reuse, rapid infiltration basins (RIBs), and the citrus freeze protection and irrigation water supply to the Water Conserv II distribution center. The RIBs are classified as a rapid-rate land application system and have a total wetted area of 261 acres. Chapter 62-610, Reuse of Reclaimed Water and Land Application, FAC, sets the treatment criteria for rapid-rate land application effluent disposal systems and the Florida Department of Environmental Protection (FDEP) requires at least secondary treatment and basic disinfection levels for rapid-rate land application systems. The FDEP also requires WCIIWRF to adhere to an effluent nitrate limit of 10 mg/L annual average and 12 mg/L weekly and monthly average for the rapid infiltration basins. Table 1 summarizes the effluent permit limits for the facility.

Table 1. Water Conserv II Water Reclamation Facility Permit Summary

Parameter	Units	Max/Min	Annual Avg.	Mon. Avg	Single Sample	Sample Freq.
Flow	mgd	Maximum	21.0	-	-	Continuous
CBOD <sub>5</sub>	mg/L	Maximum	20.0	30.0	60.0	Daily
TSS	mg/L	Maximum	20.0	30.0	60.0	Daily
Nitrogen, Nitrate, Total (as N) <sup>(1)</sup>	mg/L	Maximum	10.0	12.0	Report	Daily
Total Nitrogen <sup>(1)</sup>	mg/L	Maximum	10.0	Report	Report	Daily

(1) Nitrate and Total Nitrogen limits are from WCH Distribution Center Permit for RIBs.

Table 2. Water Conserv II Water Reclamation Facility Influent Quality (October 2016 - March 2017)

	CBOD <sub>5</sub>	TSS	TN	TKN	Ammonia	Nitrate	TP	Alkalinity
95th Percentile	320	310	53	53	37	0.36	11	289
Average	268	224	44	44	31	0.26	8	263

Table 1. Water Conserv II Water Reclamation Facility Effluent Quality (October 2015 - January 2016)

Parameter	CBOD <sub>5</sub>	Nitrate	TN	TP	TSS
95th Percentile	3.0	4.8	8.2	4.5	1.1
Max	4.2	6.3	16.5	7.7	2.0
Average	2.2	2.1	4.1	2.6	1.0

### Historical Trend

Tables 2 and 3 present recent historical trends for influent and effluent quality. Inflow to the BNR is typically balanced between the two trains, though fluctuations in the data may occur if a basin is down and flow is diverted to the other train. The effluent quality data set was taken for the four months prior to commencement of the improvements project; even before the improvements, WCIIWRF was achieving a high level of biological nitrogen removal. The IR flow is maintained at approximately twice the plant equalized flow (2Q) and RAS is maintained at approximately 0.8Q.

## Mixing Systems

### Mechanical Mixers

Vertical shaft hyperboloid mixers have a motor and gearbox mounted above the water and a vertical shaft similar to other vertical shaft impeller mixers, but the key difference is the use of a solid hyperboloid-shaped impeller instead of a multibladed impeller. The hyperboloid impeller has multiple vanes integral to the impeller that direct flow radially from the impeller; this directs flow out toward the tank walls, which then turns the flow up toward the surface. This creates counter-rotation currents around the mixer similar to vertical shaft impeller mixers, but the hyperboloid impeller also creates numerous microvortices along the floor of the tank to prevent solids from accumulating at the bottom. The hyperboloid impeller is typically located much closer to the tank floor (approximately one-tenth impeller diameter) and has a slower rotational speed. Low rotational speed reduces the potential of shearing the mixed liquor floc, which can improve settling in downstream processes.

### Big Bubble System

A big bubble mixing system provides mixing action through coordinated short bursts of com-

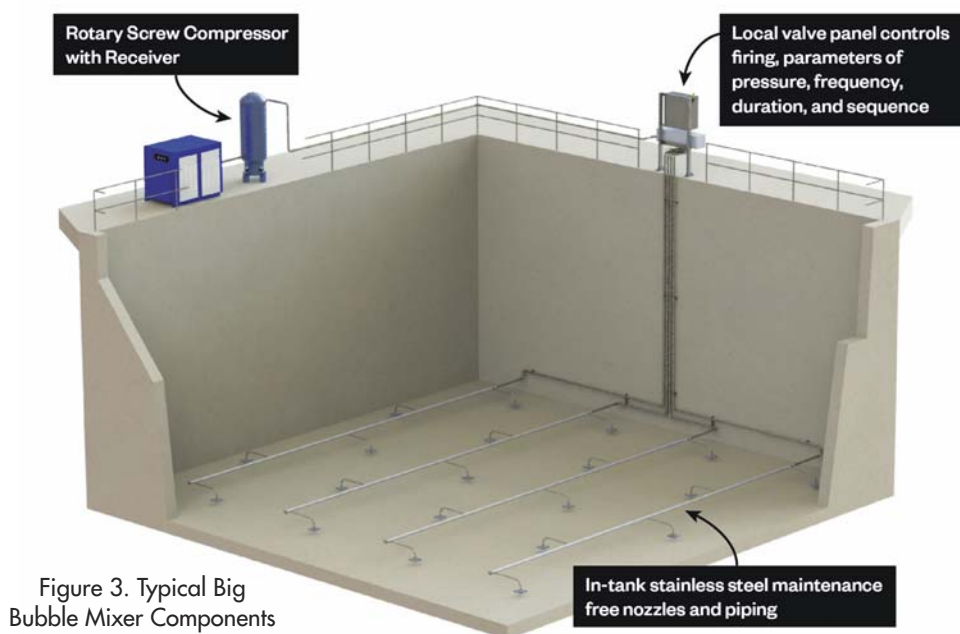

Figure 3. Typical Big Bubble Mixer Components

pressed air. The compressed air is discharged through nozzle headers installed on the floor of the tank, similar to coarse and fine bubble aeration systems; however, the large bubble system has significantly fewer nozzles than a diffuser-based system and only discharges air intermittently in timed bursts. The transfer of oxygen is dependent on the surface area of the bubbles and the surface area (per unit volume) is inversely related to the diameter of the bubbles produced (larger bubbles result in less surface area in the same volume).

Since the bubbles produced in a big bubble mixing system are much larger (approximately grapefruit-sized) than coarse and fine bubble systems, the oxygen transfer is negligible. Figure 3 shows a typical nozzle header arrangement. The air to each header is controlled by electrically actuated valves (one for each header) located in a valve control panel (VCP). Compressed air is supplied to each VCP from receiving tanks, typically one per panel, which are supplied from a common compressor. The receiving tanks and VCPs are typically mounted near the header pipes they supply. The VCPs can be programmed to fire sequentially at controlled intervals to “roll” the tank from one end to the other and achieve uniform mixing with negligible oxygen transfer.

### Design Comparison

The hyperboloid-style mixer installation requires modifications to each of the basins to accommodate hanging the mixer in the center of each basin. At basins 3 and 4, new fabricated aluminum structures could be provided to support the new mixers; at basins 7, 8, 9 and 10, the existing walkways would require modifications to the concrete infrastructure to support the mixers. Additionally, existing concrete columns supporting the walkway create constraints on mixer locations.

For this installation, big bubble mixing can provide adequate mixing for solids suspension, with a reduction in power consumption compared to hyperboloid mixers. In addition to potential energy savings, use of the big bubble mixing system requires less structural modifications to the basins for access. All moving parts of the big bubble mixing system, including the compressor and air control valving, are installed above the water line, facilitating maintenance.

Three 200-pounds-per-sq-in. (psi) air compressors (two active and one standby) are required as part of the big bubble mixing package for all six basins. A phased design of installing basins 3 and 4 now and basins 7-10 later requires only two compressors, with one serving as active and one as standby.

The compressors operate to maintain a given pressure within a precharged receiver tank. A valve panel operates to discharge air from the receiver tank into air headers for dis-

Table 4. Hyperboloid Mixer Energy Requirements

Parameter	Basins 3 & 4	Basins 7 & 8	Basins 9 & 10	Total
Quantity per Basin	4	4	2	10
Total Basins	2	2	2	--
Total Power Consumed	16.0 hp	29.6 hp	14.8 hp	60.4
Mixing Energy	0.11 hp / 1000 cf	0.15 hp / 1000 cf	0.15 hp / 1000 cf	--

Table 5. Big Bubble Mixer Energy Requirements

Parameter	Basins 3 & 4	Basins 7 & 8	Basins 9 & 10	Total
Number of Compressors (duty)	1	1	(Additional not required)	2
Total Consumed Power	16.6 hp	16.6 hp	8.4 hp	41.6
Mixing Energy	0.11 hp / 1,000 cf	0.08 hp / 1000 cf	0.08p / 1000 cf	--

Table 6. Summary of Hyperboloid Mixer Capital and Operation and Maintenance Costs

Basins 3 and 4							
	Description	Size	Quantity	Unit	Capital Cost	O&M	Total
1	Aluminum Walkway	NA	8	Ea	\$390,000	\$808,000	--
2	Mixers	3 hp	8	Ea	\$377,000		
3	Diffuser Modifications	NA	2	Ea	\$64,000		
4	Electrical Improvements	NA	8	Ea	\$128,000		
Subtotal					\$959,000	\$808,000	\$1,767,000
Basins 7 - 10							
	Description	Size	Quantity	Unit	Total	O&M	Total
1	Walkway Modifications	NA	12	Ea	\$270,000	\$1,409,000	--
2	Mixers	5 hp	12	Ea	\$659,000		
3	Diffuser Modifications	NA	3	Ea	\$96,000		
3	Electrical Improvements	NA	12	Ea	\$192,000		
Subtotal					\$1,216,000	\$1,409,000	\$2,625,000
Total Capital Cost					\$2,175,000	--	--
Total O&M Cost					--	\$2,217,000	--
Total Lifecycle Cost					--	--	\$4,392,000

tribution into each basin. Once distributed, small-diameter-type 316SS piping distributes flow to the nozzles, which are arranged and installed around the existing diffuser grid and mounted directly to the basin floor. This preliminary design indicated a total power consumption requirement of 41.7 horsepower (hp).

The number of mixers and nozzles that are required for each design are based on requiring 0.11 and 0.08 hp/1,000 cu ft (ft<sup>3</sup>) of aerated basin floor for basins 3-4 and 7-10, respectively. Tables 4 and 5 present the amount of hp that is required based on the amount of mixing energy. These hp requirements are the basis for energy consumption.

### Life Cycle Analysis

To provide the city with an equal basis for deciding between the hyperboloid mixers and big

bubble mixers, costs were evaluated on a life cycle analysis. For each type of mixer, the capital, electrical, and maintenance costs were included. Each mixer type required modifications to the existing fine bubble tube diffusers to pin them to the basin floor or provide a clear space around the mixer.

Additionally, the hyperboloid mixers required that aluminum walkways be constructed to support the mixers within the center of the basin, and the big bubble mixers included a pre-engineered steel building construct above the compressors.

Table 6 presents a summary of the capital and operation and maintenance (O&M) costs for the current project (basins 3 and 4), as well as estimates to install hyperboloid mixers into basins 7-10. The capital cost includes 20 percent contingency and 25 percent contractor overhead and profit.

Table 7 presents a summary of the capital  
*Continued on page 10*

Table 7. Summary of Big Bubble Capital and Operation and Maintenance Costs

Basins 3 and 4							
	Description	Size	Quantity	Unit	Capital Costs	O&M	Total
1	Compressor slab/roof	NA	1	Ea	\$53,000	\$1,151,000	--
2	Big Bubble Mixers/Compressor	NA	1	Ea	\$829,000		
3	304 Stainless Steel Piping	3 in	250	LF	\$15,000		
4	Diffuser Modifications	NA	1	Ea	\$65,000		
5	Electrical Improvements	NA	2	Ea	\$115,000		
<b>Subtotal</b>					\$1,077,000	\$1,151,000	\$2,228,000
Basins 7 - 10							
	Description	Size	Quantity	Unit	Capital Costs	O&M	Total
1	Compressor slab/roof	NA	1	Ea	\$53,000	\$738,000	--
2	Big Bubble Mixers/Compressor	NA	1	Ea	\$956,000		
3	304 Stainless Steel Piping	3 in	750	LF	\$44,000		
4	Diffuser Modifications	NA	1	Ea	\$96,000		
5	Electrical Improvements	NA	1	Ea	\$58,000		
<b>Subtotal</b>					\$1,207,000	\$738,000	\$1,945,000
<b>Total Capital Cost</b>					\$2,284,000	--	--
<b>Total O&amp;M Cost</b>					--	\$1,889,000	
<b>Total Lifecycle Cost</b>					--	--	<b>\$4,173,000</b>

Table 8. 20-Year Net-Present-Worth Life Cycle Analysis: Hyperboloid Mixers and Big Bubble Mixing System

Parameter	Hyperboloid Mixers	Big Bubble Mixers	Difference
<b>Capital Cost</b>	\$2,175,000	\$2,284,000	+\$109,000
<b>Operation and Maintenance Cost</b>	\$2,217,000	\$1,890,000	-\$327,000
<b>Total Life Cycle</b>	\$4,392,000	\$4,174,000	-\$218,000

Continued from page 9

and O&M costs for both the current project, as well as estimates to install the big bubble mixer system into Basins 7-10. The capital cost includes a 20 percent contingency and 25 percent contractor overhead and profit.

Capital, electrical, maintenance, and re-building costs were estimated over a 20-year life cycle to equitably compare both of the mixing systems. Though the capital cost of the big bubble mixing system was slightly higher, the expected O&M costs were slightly lower, with both costs being within the applied contingency. Table 8 presents the 20-year life cycle analysis of the two systems.

### Big Bubble Design Description

Based on the life cycle analysis, the city decided to move forward with final design and bidding of the big bubble mixing system. The project was bid with a base bid to include the work within basins 3 and 4, and an alternate bid to include the work in all basins. Due to budgetary reasons, the base bid was selected, and the big bubble mixing system was installed within basins 3 and 4. Installation of a mixing system in basins 7-10 was deferred.

For basins 3 and 4, there are 12 nozzle headers in each basin. Each header has six nozzles, for a total of 72 nozzles in each basin. Each basin has two VCPs, each with six valves, which supply air to the headers. Each VCP has a dedicated receiver tank located adjacent to the panel that keeps the system pressurized. Two compressors (one duty and one standby) are located adjacent to the aeration tanks, and are housed under a new canopy structure for protection of equipment and staff during maintenance. Due to ease of installation, press-fit stainless steel piping was utilized for the mixing system air piping. The master control panel is located in an adjacent electrical room and contains the control screen, with various parameters that can be adjusted, including pressure (25-30 psi), valve firing frequency, valve firing duration, and valve firing sequence. The parameters allow the operators to fine-tune the system and can provide operational flexibility; if desired, a portion of the system could be kept in mixing mode while another portion is aerated. Mixing and aeration can also be operated simultaneously, if desired. Figure 4 presents a schematic view of the locations of the mixing system equipment; not shown are the compressors that feed the receivers.

### Results of Project

#### Mixing Performance Testing

Full-scale mixing testing was performed as a contract requirement and to ensure that the

Continued on page 12

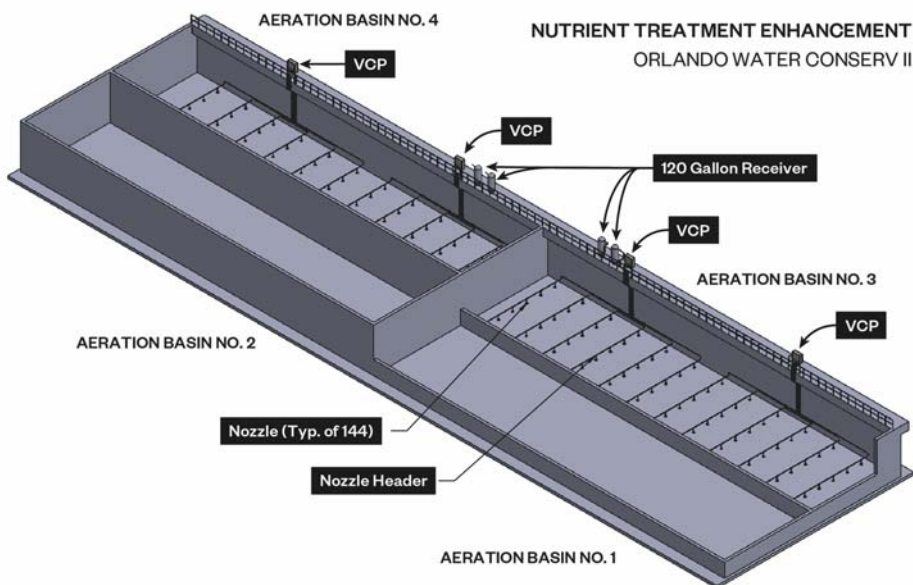

Figure 4. Conserv II Water Reclamation Facility Big Bubble Mixer Schematic

Figure 5. Sample Locations Within Aeration Basin No. 4



Table 9. Basin No. 4 Mixing Test Results (7/25/2016)

Sample No.	Depth	TSS Concentration (mg/L)
A	Top	3,850
	Mid-depth	3,750
	Bottom	3,800
B	Top	3,750
	Mid-depth	3,750
	Bottom	3,950
C	Top	3,800
	Mid-depth	3,750
	Bottom	3,850
D	Top	3,800
	Mid-depth	3,800
	Bottom	3,900
E	Top	3,750
	Mid-depth	3,900
	Bottom	3,800
F	Top	3,800
	Mid-depth	3,700
	Bottom	3,900
Standard Deviation:		68
Mean:		3,811
Coefficient of Variation:		1.8%

Table 10. Nutrient Tracking Through Basins

Parameter	Influent	3 & 4 (Anoxic)	1 & 2 (Aerobic)	5 & 6 (Aerobic)	7 & 8 (Anoxic)	9 & 10 (Anoxic + Reaer)
Ammonia - N	31.0	8.0	2.4	0.5	0.6	0.4
Nitrate - N	--	0.7	0.4	0.8	0.6	0.1
Nitrite - N	0.3	0.7	6.0	6.9	1.9	0.5
TIN	31.3	9.4	8.8	8.2	3.1	1.0

Table 11. Conserv II Water Reclamation Facility Effluent Quality (October 2015 - January 2016)

Parameter	CBOD5	Nitrate	TN	TP	TSS
95th Percentile	3.0	4.8	8.2	4.5	1.1
Average	2.2	2.1	4.1	2.6	1.0

Continued from page 10

big bubble mixers were keeping the contents of basins 3 and 4 completely mixed. Typically, total suspended solids (TSS) measurements are made across the basins at various depths. The data are collected and analyzed to confirm that the coefficient of variation (Cv) of the TSS concentrations from each tank are  $\leq 10$  percent, indicating uniform basin contents. Due to aeration basins 3 and 4 being geometrically similar, only one basin was tested.

The mixing system default-firing parameters are as follows:

- ◆ Frequency is the interval between complete cycles of firing the valves in each VCP in the defined sequence. The frequency during testing was 25 seconds.
- ◆ Sequence is the order in which each VCP fires to complete a single cycle. The sequence during testing was 1-2-3-4-5-6 (all valves fired once in order, then repeated).
- ◆ Duration is the length of time each air control valve remains open. The duration during testing was 0.5 seconds.

The TSS measurements were obtained with a portable, handheld TSS analyzer, Cerlic Model C83C5EN11. The sample site locations for each zone are shown in Figure 5. Three samples were collected at each sampling location in the tank: approximately 18 in. below the surface, mid-depth, and 18 in. above the tank floor.

The average measured concentration within each zone ranged from 3,700 to 3,900 mg/L; the concentration did not vary significantly along the length of the basin. The calculated Cv from this testing was approximately 1.8 percent, which is significantly less than the 10 percent typically allowed for mixing systems. The results in Table 9 indicated uniform basin contents.

### Nutrient Removal Enhancement

Table 10 shows the average concentrations of each pair of basins through the biological treatment trains. Since the installation of the mixers, the system has seen enhanced nutrient removal and treatment performance stability. Prior to the installation of the big bubble mixers, ammonia and nitrate concentrations leaving basins 1-4 were variable due to the difficulty of denitrifying in an aeration using fine bubble aeration to provide mixing.

Prior to the upgrade leaving basins 1-4, nitrate concentrations typically were between 5 and 10 mg/L, while ammonia concentrations varied more dramatically at 1 to 20+ mg/L. After the mixers were installed, ammonia concentrations leaving Basins 1-4 were approximately 8 mg/L, while the nitrite and nitrate concentra-

tions were typically less than 1 mg/L.

The low nitrate levels demonstrate the enhanced performance of the first anoxic zones with the big bubble mixing. This high level of treatment within the first four basins occurs in only 2.24 mil gal of tankage, or approximately 32 percent of the total aeration tankage of the facility. The facility is able to achieve partial nitrification and nearly complete denitrification within basins 1-4 in a relatively short nominal detention time (approximately 3.4 hours).

## Conclusions

This successful project for the city resulted in construction of an energy-efficient mixing system, with low maintenance for the city. The mixing system enhanced denitrification within the biological process and improved overall plant performance, as can be seen in Tables 11 and 12. The four-month effluent snapshots represent the four months prior to the start of the improvements project and the same four months following project completion. The facility consistently achieves effluent total nitrogen (TN) concentrations well below what is typically accepted as the limit of technology (TN < 3 mg/L). In addition to the mixing system, the combination of mixing and aeration in the same tank and the unique internal recycle flow scheme allows for basins to be taken offline without significantly impacting plant performance.

Figure 6 provides a visual comparison of the effluent quality and stability before and after the improvements were completed. Not only has effluent quality improved since the project, but ease of operation has also improved. The biological system was enhanced because of the increased mixing and the use of true anoxic basins.

In addition to improving overall effluent quality and providing for operational flexibility of the BNR process, installation of the mixing system appears to have improved the time for the facility to recover following high-flow events, such as hurricanes. Figure 7 presents an expanded graph of effluent TN and nitrate concentrations; the spike in nitrogen shown in October 2016 was due to Hurricane Matthew and the spike in nitrogen shown in September 2017 was due to Hurricane Irma. The big bubble mixing system improved plant resiliency and allowed for a quicker recovery of effluent quality following the high inflow.

Based on the increase in facility performance from the successful project, the city has decided to move forward and expand the remainder of the big bubble mixing system in Basins 7-10.

Table 12. Conserv II Water Reclamation Facility Effluent Quality (October 2016 - January 2017)

Parameter	CBOD <sub>5</sub>	Nitrate	TN	TP	TSS
95th Percentile	3.4	1.7	3.3	4.6	1.4
Average	2.3	0.6	1.7	2.6	1.3

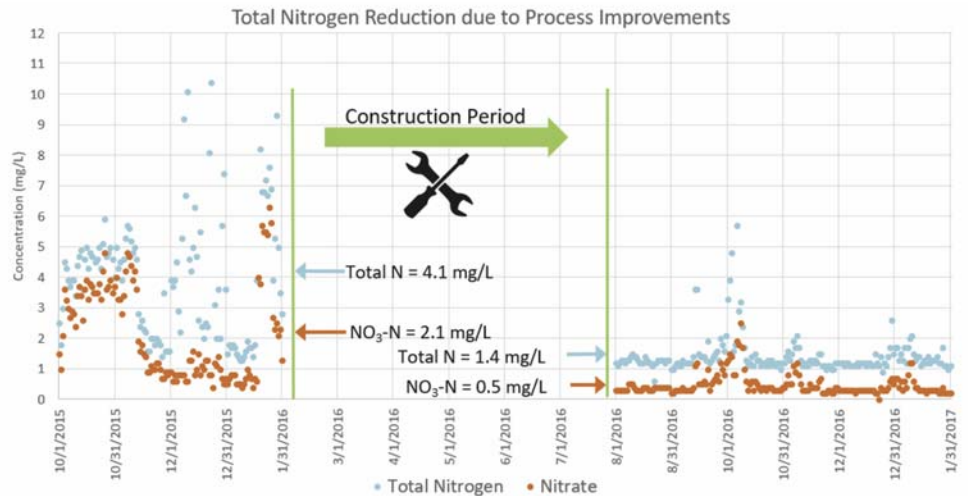

Figure 6. Big Bubble Mixing System Improves Effluent Quality

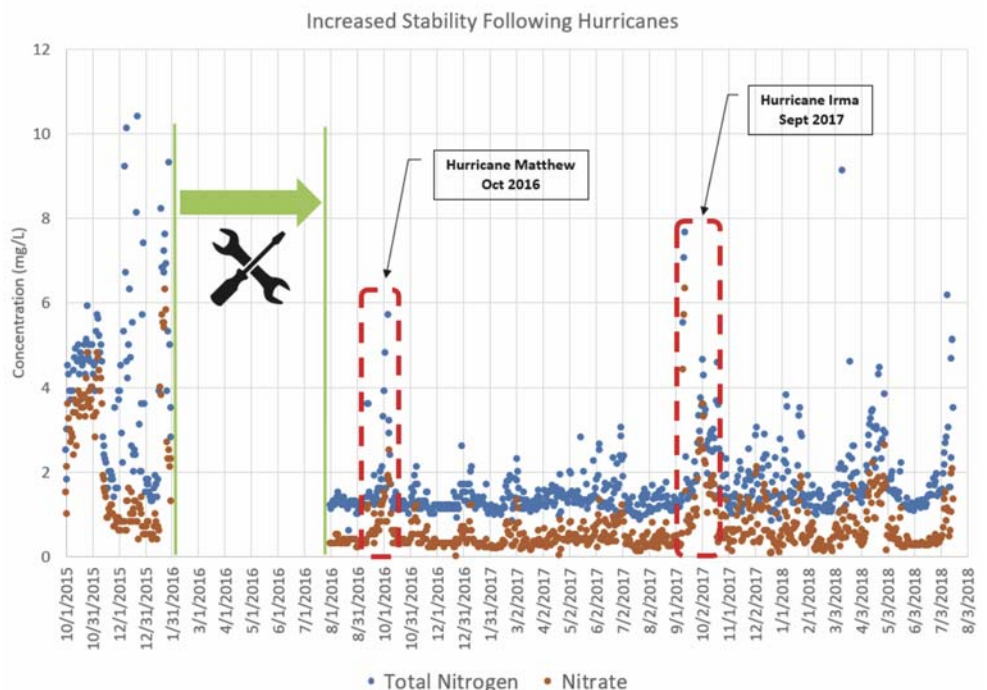

Figure 7. Conserv II Water Reclamation Facility Quick Recovery Following Hurricanes